

压力传感器 Pressure sensor

RPT8200系列

应用于工程机械、船舶、高速列车、机床、航空、自动化
医疗、冶金、电力等领域

- 性能稳定，优异的EMC性能
- 通过高低温、盐雾、温湿度测试
- 抗高频震动、冲击
- 防护等级可达IP67
- 符合RoHS，CE认证
- 可定制防爆及特殊型号



外形尺寸图 Dimensions:(mm)

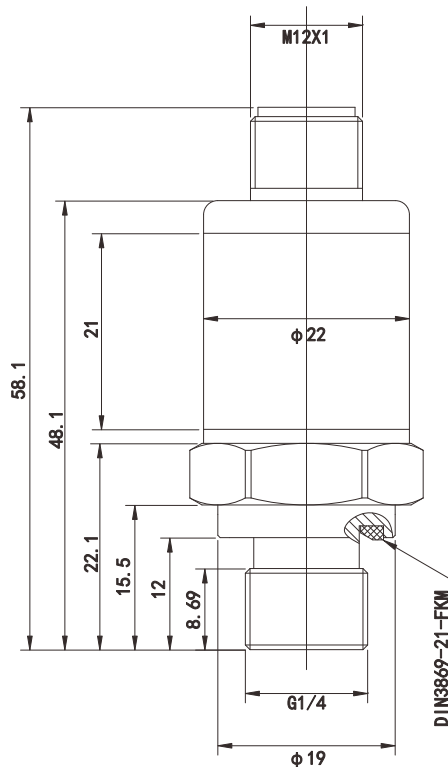

技术参数 Technical Parameter		
参数	Specifications	技术指标 Technical Data
输入数据	Input Data	
压力范围	Measuring ranges	-1~1...10...16...25...50...60...100...250...400...600...1000
过载压力	Overload pressures	300%F.S 150%F.S
爆破压力	Burst pressures	500%F.S 200%F.S
机械接口	Mechanical connection	G1/4-A 7/16-20UNF-2A 1/4-18NPT/NPTF G3/8-A
锁紧扭力	Torque value	20N.m 12N.m 40N.m
介质接触物	Parts in contact with	Mech connection:Stainless steel Seal:FKM 17-4PH
输出数据	Output data	
输出信号	Output signal	4~20mA 0~5V 1~5V 0~10V 1~10V 0.5~4.5V
精度	Accuracy to DIN 16086	$\leq \pm 0.25\%F.S$ trp $\leq \pm 0.1\%F.S$ trp
	Max.setting	$\leq \pm 0.5\%F.S$ max $\leq \pm 0.3\%F.S$ max
非线性	Non-linearity at max.setting	$\leq \pm 0.3\%F.S$ max $\leq \pm 0.1\%F.S$ max
迟滞性	Hysteresis	$\leq \pm 0.1\%F.S$ max
重复精度	Repeatability	$\leq \pm 0.05\%F.S$
压力上升时间	Rise time	≤ 1 ms
响应时间	Response time	≤ 0.5 ms
长期稳定性	Long-term drift	$\leq \pm 0.1\%F.S$ trp./year
环境条件	Environmental conditions	
温度补偿	Compensated temperature range	-25~+85°C
工作温度	Operating temperature range	-40~+125°C
储存温度	Storage temperature range	-40~+135°C
流体温度	Fluid temperature range	-40~+125°C
EMC抗干扰	EMC Test	EN 6100-4-2/3/4/5
耐振性	Vibration resistance to	≤ 20 g
	DIN EN 60068-2-6 at 10~2000Hz	
冲击	Impact	30g
负载	Load	RL $\geq 5k\Omega$
防护等级	Protection class to DIN 40050	IP67, IP68
其他数据	Other data	
工作方式	Operational Mode	绝压, 表压 Absolute, Gauge
工作电压	Operating voltage	24VDC(9~32VDC), $5 \pm 10\%VDC$
供电电流	Power supply current	<10mA
极性保护	Polarity protection	$\geq 32VDC$ $\geq 28VDC(5 \pm 10\%VDC$ 供电压力传感器)
耐电压保护	Resistance to voltage	protection $\geq 50VDC$
		$\geq 28VDC(5 \pm 10\%VDC$ 供电压力传感器)

选型表 Model code

RPT82 X X-X-XX-XXXX-X(000)

电气接口 Electrical connection

- 0=flying lead
- 1=M12X1 EN60947-5-2
- 2=3 pole+PE,DIN43650,male
- 5=客户定制

机械接口 Mechanical connection

- 1=7/16-20UNF-2A
- 2=1/8-27NPT
- 3=1/4-18NPT
- 4=G1/4-A DIN3852-E
- 5=G1/2-A DIN3852(male)
- M=客户定制

输出信号 Signal

- A=4~20mA,2conductor
- B=0~10V,3conductor
- C=1~10V,3conductor
- D=1~5V,3conductor
- E=0~5V,3conductor
- F=0.5~4.5,3conductor

精度 Precision

- 01=0.1%
- 02=0.25%

压力范围 (bar) Pressure ranges in bar

- 0001=0~1bar
- 0050=0~50bar
- 0400=0~400bar
- 1000=0~1000bar
- (压力范围 -1~1000bar可选)

工作方式 Operational Mode

- A=绝压 Absolute
- G=表压 Gauge

导线 Modification number

- 000=不带连接线
- 020=2m 电缆线 (含接头)
- 050=5m 电缆线 (含接头)

接线定义 pin connections:

M12X1 4-pole male

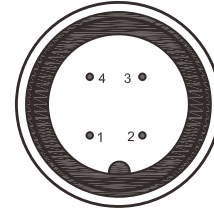

pin	RPT82XX-A	RPT82XX-B
1	+24VDC	+24VDC
2	n.c.	0~10VDC
3	4~20mA	GND
4	n.c.	n.c.

DIN43650

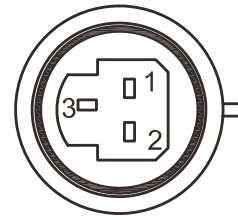

pin	RPT82XX-A	RPT82XX-B
1	4~20mA	GND
2	+24VDC	+24VDC
3	n.c.	0~10VDC

Fly lead

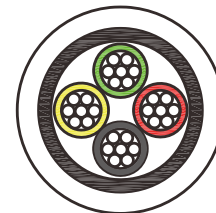

Core	RPT820X-A
red	+24/+5VDC
black	Signal
yellow	GND
green	n.c.